

Isometric View

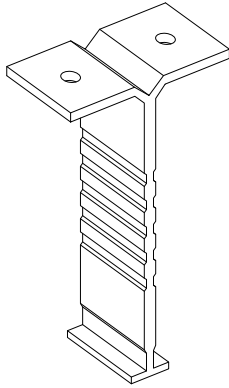

Top View

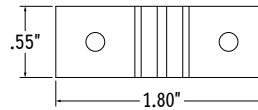

End View

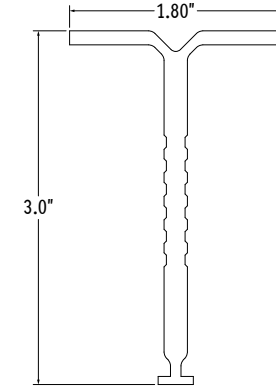

1. Measure area where LLED8200-RPM will be installed.
RECOMMENDATION: Use chalk line to ensure a straight installation.

2. Mark location where mounting brackets will be installed.
NOTE: 1 mounting bracket required every 2'.

3. Slide required number of mounting brackets into channel on extrusion.

4. Place end caps on both ends of extrusion, then insert lead wires through end cap and opening in mounting surface.

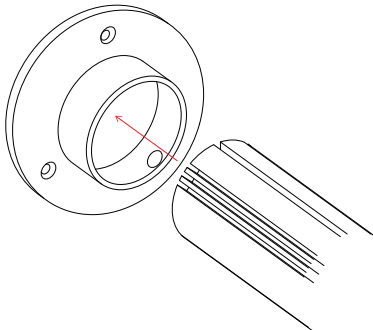

5. Screw mounting brackets to mounting surface, then screw end caps to mounting surface. Ensure fixture and all fastenings are secured in place.

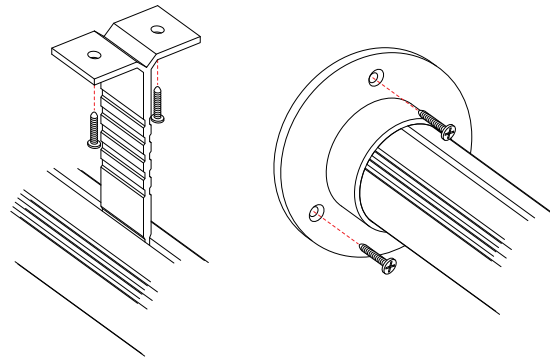

6. Apply silicone at both ends of each run to seal fixture (for wet location fixtures only).

Assembled End View

