

READ ENTIRE GUIDE BEFORE STARTING INSTALLATION

IMPORTANT NOTICE: VERIFY CORRECT LUMINAIRE WAS RECEIVED WITH CORRECT COLOR TEMPERATURE, VOLTAGE, AND WATTAGE BEFORE CUTTING OR INSTALLING. CALI WILL NOT BE RESPONSIBLE IF INCORRECT LUMINAIRE IS INSTALLED.

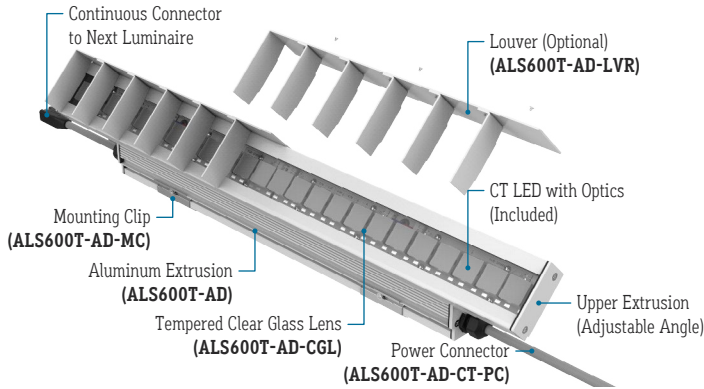

GENERAL FEATURES

APPLICATIONS	Wall Washing Lighting
LENS	Tempered Clear Glass Lens
OPTICS AND ASYMMETRIC	10° - 60° or Asymmetric Optics
LENGTH	Built to Order (2', 3', or 4' Increments)
CONSTRUCTION	Aluminum Extrusion
DRIVER	Integral
WEIGHT	5.6 lbs (2'), 7.9 lbs (3'), 11.2 lbs (4')
MOUNTING	Mounting Clips
LISTING	Dry or Wet (IP65 or IP67) Location UL1598, CSA C22.2#250.0 UL8750, CSA250 UL2108, CSA C22.2 #9
TEMPERATURE RATINGS	Operating / Startup: -20° to 48°C (-4° to 120°F) Storage: -40° to 76°C (-40° to 170°F)

ELECTRICAL

DIMMING	0-10V, DMX, DALI (Type 6), Lutron
MAXIMUM RUN	40' (1.5W, 2W, 3W, 4W, 5W, 6W, 7W)
LUMINAIRE VOLTAGE	120V - 277V (UNV)

COMPATIBLE CONTROL INTERFACES

- 0-10V
- Distech Controls
- Crestron / Cresnet / SolarSync
- DALI2
- Legrand
- Eaton
- DMX
- Wattstopper
- Tridonic / Bluetooth
- Acuity Controls / nLight
- Pass & Seymour
- Lutron
- eldoLED
- Leviton

END VIEWS

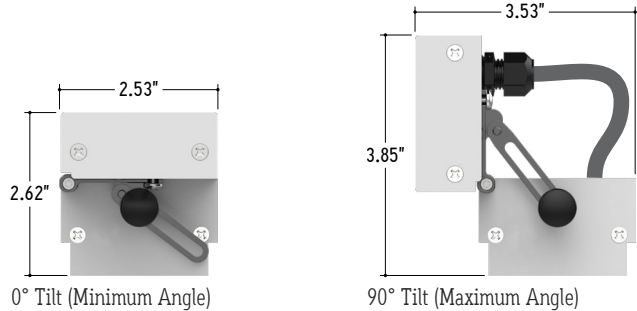

PRODUCT INFORMATION

- Lighting for wall washing, cove, edge, undercabinet, accent, displays
- Line Voltage (Integral Driver)
- Choose from a variety of LED colors and whites
- Available in 3 Watts up to 7 Watts Per Foot
- Product is shipped in 1', 2', 3', and 4' luminaires
- Available for outdoor rated installations

ELECTRICAL

- Line Voltage luminaires do not require a remote driver.
- Maximum load per line voltage fixture is 320 watts per circuit

INSTALLATION RECOMMENDATIONS

- AlumLEDs can be mounted to sheetrock, concrete, or wood using proper mounting screws .
- All wiring is enclosed inside aluminum housing .
- Provide run lengths at time of order.
- AlumLEDs is suitable for indoor (Dry) or outdoor (IP65 or IP67) applications.

INSTALLATION TOOL REQUIRED

- Electric Hammer Drills (optional)
- Long Nose Pliers
- 14.4 to 28 Volt Cordless Drills
- Drill Bits - Concrete or Wood
- Phillips Bits - Sufficient Quantity
- Electrical Three Ways
- Utility Knife
- Safety Glasses
- Electrical Cords
- Measuring Tapes
- Marker
- Chalk Line
- Wire Strippers

WARNING

When using alumLEDs for any application, basic safety precautions should always be followed to reduce the risk of fire, electric shock, and personal injuries.

AlumLEDs must be installed in accordance with the NEC or CEC as applicable.

CALI will not be responsible for any damage or malfunction caused by the following:

- Ensure power is off before installation begins, during replacements, additions, or repairs.
- Do not use alumLEDs if damaged, such as broken boards, loose connections, or frayed wire insulation. Inspect before installing.
- Do not install alumLEDs in hazardous locations.
- Do not cover alumLEDs with any material. Covering may cause LEDs to overheat, melt, or ignite.
- Do not paint on or over fixture lens or LEDs.
Paint or any other substance on lens or LEDs will cause a shift in color temperature.
- Soffit must be evenly painted with a neutral white to avoid color shift.
- Do not modify alumLEDs in the field.
- Do not overlap alumLEDs luminaires in any way. (Fig. 1)
- alumLEDs have line voltage risk of shock. Consult factory for any malfunctions.
Do not attempt to repair.
- Only use alumLEDs with specified rated voltages. Do not exceed the specified voltage for any alumLEDs luminaire.
- Do not use alumLEDs extrusion as a raceway for additional wire. Non-factory feed through wires inside alumLEDs will void warranty.
- Ground Fault Circuit Interrupter (GFCI) protections should be provided on circuits or outlets when alumLEDs is used for outdoor applications.
- Surge protector must be set up for electrical power system to avoid damaging alumLEDs lighting system.
- Do not connect wires together, follow provided wiring diagrams.
- Do not cut wire while energized. (Fig. 2)
- Do not exceed maximum run lengths.
- Do not secure alumLEDs with nails or like means that might damage the wiring inside.
Only secure by using mounting clips.
- Do not mount alumLEDs inside tanks or enclosures of any kind.
- Do not install downward facing luminaires without set screws.
- Do not use improper screw head type on mounting clips. It will cause the mounting clip to open up and become dysfunctional.
- Do not modify mounting clips.
- Do not mount fixture with less than the minimum number of mounting clips required.
See mounting clips section for details.
- Do not force alumLEDs into a space that is too small.
- Do not force alumLEDs with cord grip into soffit. (Fig. 3)
- Do not install alumLEDs at an angle within a cove.
Only install fixtures straight within a cove. (Fig. 4)
- Do not bend extrusion around radius.
- Do not submerge dry or wet location alumLEDs in any liquid.
- Do not install wet location in outdoor coves without proper drainage. (Fig. 5)
- Do not install alumLEDs in any area that is continuously exposed to flowing or pooling water, such as underneath drain pipes, sprinklers, fountains, misters, etc.
- Do not cut, puncture, or penetrate alumLEDs aluminum housing, end caps, or lens covers.
- Do not drop, bang, or rest weight upon alumLEDs.
- Do not apply excessive pressure to any part of alumLEDs.
- Do not remove end caps from alumLEDs.
- Do not bend alumLEDs power cord or continuous connector past permitted bend radius.
Bending past permitted bend radius will break the seal of the cordgrip or damage the insulation. (Fig. 6)
- Wet Location: 3.5" minimum bend radius
- Dry Location: 1.5" minimum bend radius
- Do not install alumLEDs in places where the power cord is subject to continuous flexing.
- Do not twist continuous connector or power cord.
- Do not hold, carry, or suspend alumLEDs by the power cord.
- Do not install alumLEDs on ceilings without mounting clips and set screws. (Fig. 7)

FIGURES

Fig. 1

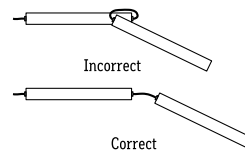

Fig. 2

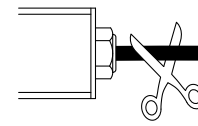

Fig. 3

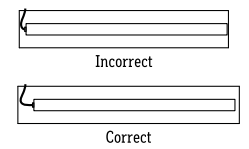

Fig. 4

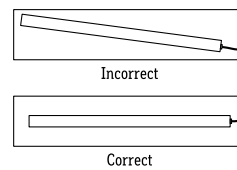

Fig. 5

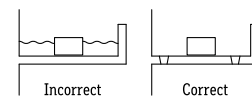

Fig. 6

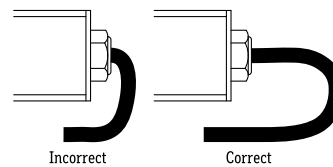
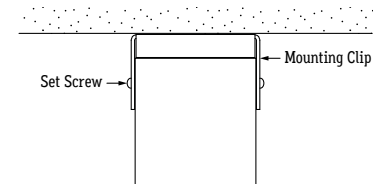

Fig. 7



CLEANING MATERIALS

The use of solvents and/or cleaners which are not compatible with polycarbonate will result in the softening, crazing, and/or cracking of the plastic part. This is especially true of polycarbonate lamps and mounting bases which may be under stress in their normal applications.

COMPATIBLE WITH POLYCARBONATE

- Mild soap and water
- Mineral Spirits
- Isobutyl alcohol
- VM and P Naphtha
- Varsol No.2
- Mexane
- Freone TF and TE-35
- Ethanol
- Dirtex
- 2% Sol. Reg. Joy
- 10% Sol Bon Ami
- White Kerosene
- Methyl alcohol
- Heptane
- Petroleum Ether/65 degrees C
- Isopropyl alcohol
- Lacryl PCL-2035 polycarbonate cleaner

NOT COMPATIBLE WITH POLYCARBONATE

- Trichlor
- Gasoline
- Liquid Detergents
- Acetone
- Carbon Tetrachloride
- Pink Lux (Phosphate free)
- Triclene
- Chlorinated Hydrocarbons
- #1 & #3 denatured alcohol
- Methyl Ethyl Keytone (MEK)
- Texize-8006, 8129, 8758
- MIBK
- Liquid Cleaner - 8211
- Toluol
- Agitene
- Benzol
- Ajax
- Kleenol Plastics
- Lysol
- Stanisol Naphtha
- Oils
- Lemon Joy (phosphate free)
- Diversol
- Lestoil

0-10V WIRING DIAGRAM (Dry Location Only)

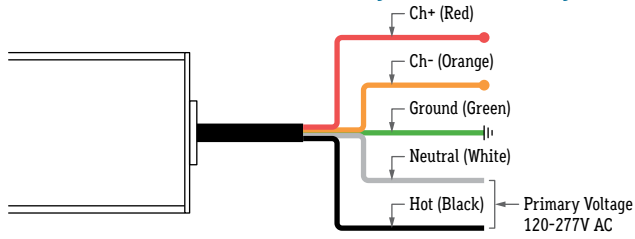

0-10V WIRING DIAGRAM (Dry or Wet Location)

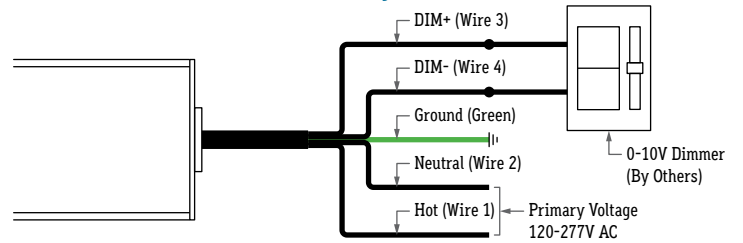

DMX WIRING DIAGRAM (Dry or Wet Location)

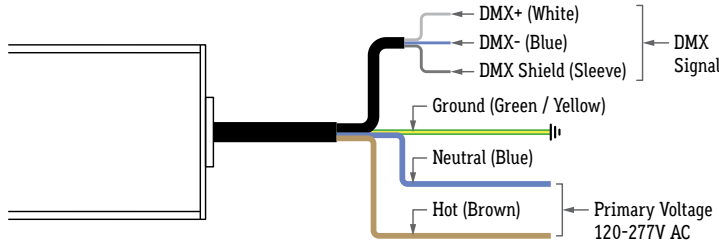

DALI WIRING DIAGRAM (Dry or Wet Location)

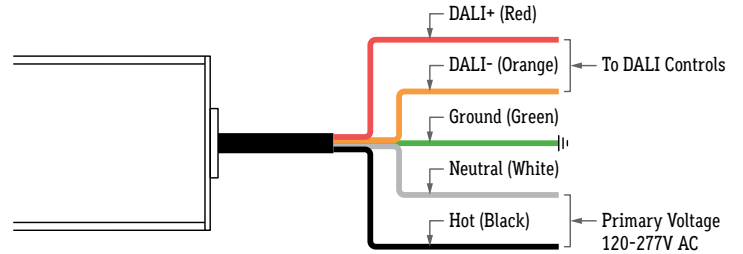

NOTES

- Consult third party DMX commissioner to modify at time of installation.
- Connection from DMX controller to luminaire must be made using a proper daisy chain connection per DMX-512 / RDM standards.
- Do not make DMX wiring connections in parallel.
- When connecting DMX Shield to a DMX controller terminal, ensure that it is not connected to or touching earth ground, chassis ground, and/or DC power (-) return.

NOTE

- DALI commissioning to be performed by a third party at time of installation. CALI does not provide DALI commissioning.

CONTINUOUS RUN

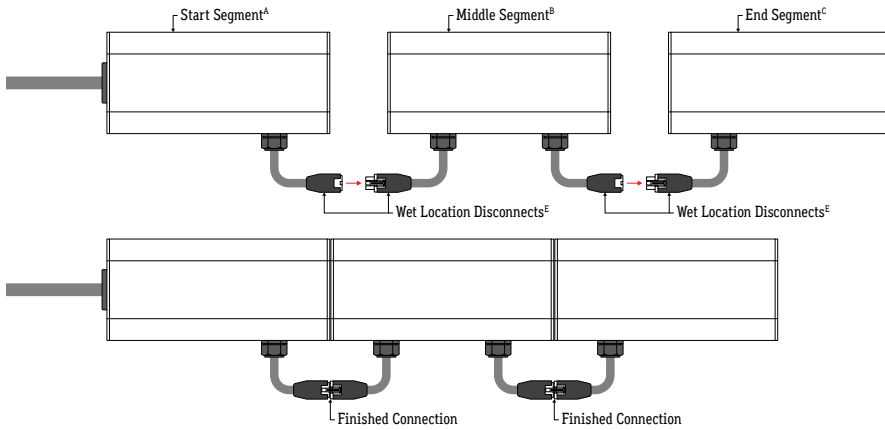

RUN WITH JUMPER CABLE (Wet Location)

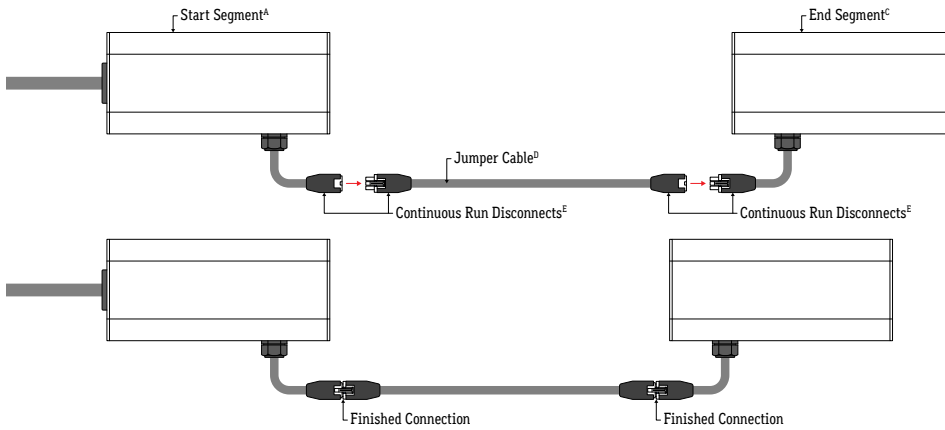

A	Start Segment: The first segment a run. One end has assembled power lead, and the other end has Continuous Run Disconnects.
B	Middle Segment: The middle segment of a run. Each end has Continuous Run Disconnects.
C	End Segment: The last segment of a run. One end has Continuous Run Disconnects, and the other end has an End Cap.
D	Jumper Cable: Used when a gap is needed between two segments on the same circuit.
E	Continuous Run Disconnects: Used to connect a segment to the next segment in line, or an accessory such as a Jumper Cable.

1 Measure area where luminaire will be installed. Use a laser line to create a reference along installation area, ensuring accurate placement of mounting clips. Mark location where each mounting clip will be installed along reference line.

2 Use 2 mounting clips per luminaire segment.
Example: 4' + 4' + 2' = 2 MC + 2 MC + 2 MC = 6 MC total.

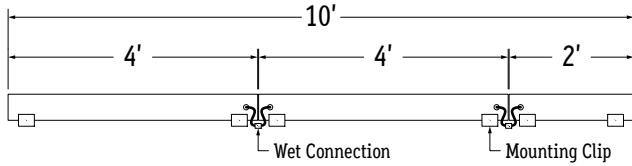

3 Lay mounting clips along reference line and pre-drill surface using an appropriate drill bit for surface and screw size.

Recommendation: 8/32 x 1" Screw.

Note: Allow 1/4" clearance for lateral expansion of assembled mounting clips. Only install mounting clips on flat, even surfaces.

4 Screw MC-1 mounting clips to surface, then snap luminaire into mounting clips. Install set screws if required. Set screws are required for downward and outward facing applications.

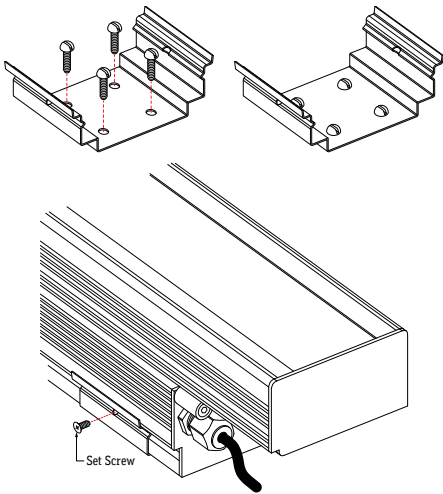

ASSEMBLED END VIEWS

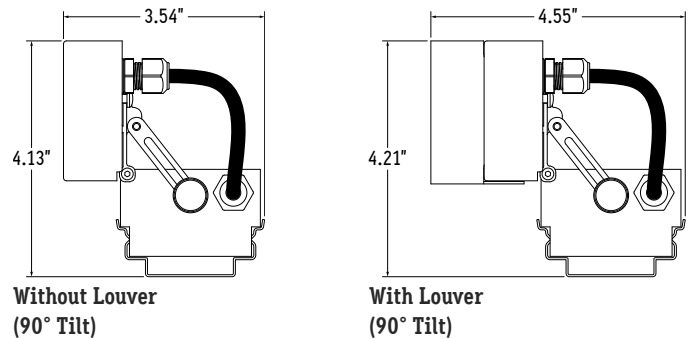
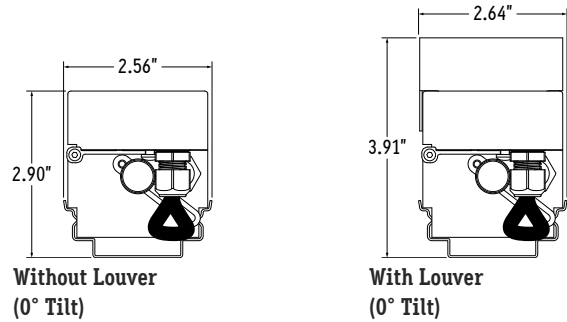

- 1 Measure area where luminaire will be installed. Use a laser line to create a reference along installation area, ensuring accurate placement of mounting clips. Mark location where each mounting clip will be installed along reference line.

- 2 Use 2 mounting stakes per luminaire segment.
Example: 4' + 4' + 2' = 2 MC + 2 MC + 2 MC = 6 MC total.

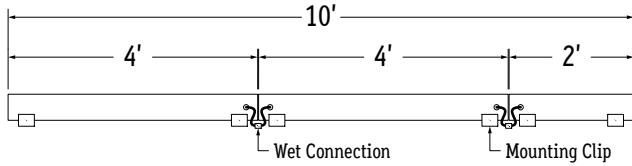

- 3 Insert stakes into the ground until entire tapered portion is submerged. The ground must be dense enough to support the weight of the luminaires. Do not install stakes into soft or loose ground.

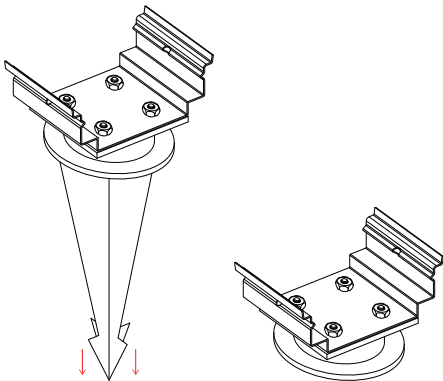

- 4 Ensure each stake is secure in place, then snap luminaires into mounting clips.

- 5 If applicable, connect disconnects between luminaire segments. Slide shrink tube over connectors and apply heat. The shrink tube will shrink down, sealing the connectors. Apply silicone around sealed connectors for a stronger seal.

Note: Only use a heat gun to apply heat to shrink tubes. Do not use an open flame such as a lighter or gas torch.

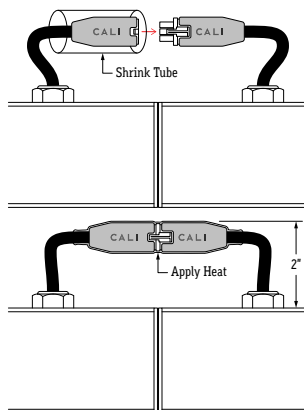

- 1 Measure area where luminaire will be installed. Use a laser line to create a reference along installation area, ensuring accurate placement of mounting clips. Mark location where each mounting clip will be installed along reference line.
- 2 The number of required mounting clips differs for dry and wet location products. Verify number of mounting clips is appropriate for installation environment before beginning installation. Do not install luminaires with inadequate number of mounting clips. Refer to the Mounting Clips page for additional information.
- 3 Lay mounting clips along reference line and pre-drill surface using an appropriate drill bit for surface and screw size.
Recommendation: 8/32 x 1" Screw.
Note: Allow 1/4" clearance for lateral expansion of assembled mounting clips.
Only install mounting clips on flat, even surfaces.
- 4 If applicable, connect disconnects between luminaire segments. Slide shrink tube over connectors and apply heat. The shrink tube will shrink down, sealing the connectors. Apply silicone around sealed connectors for a stronger seal.
Note: Only use a heat gun to apply heat to shrink tubes. Do not use an open flame such as a lighter or gas torch.

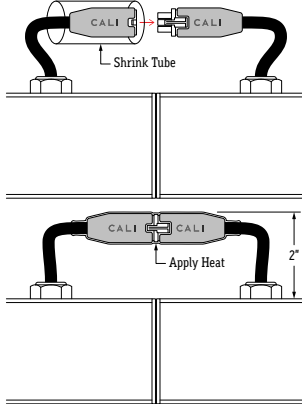

- 5 Screw MC-1 mounting clips to surface, then snap luminaire into mounting clips. Install set screws if required. Set screws are required for downward and outward facing applications.

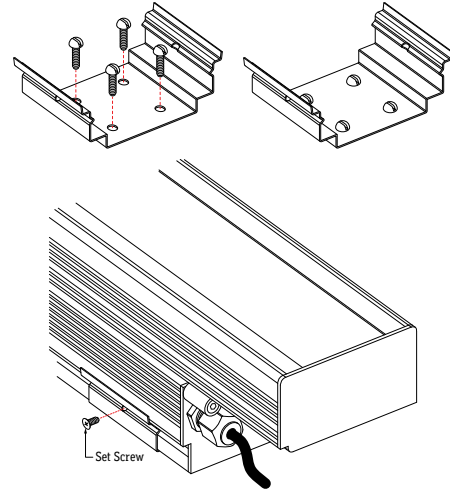

- 6 Perform a continuity test before connecting luminaire to power source. Refer to Troubleshooting & Continuity Test page for additional information.
- 7 Verify wiring diagram, then connect luminaire to power source.

- 1 Measure area where luminaire will be installed. Use a laser line to create a reference along installation area, ensuring accurate placement of mounting arms. Mark location where each mounting arm will be installed along reference line.
- 2 Determine number of mounting arms needed. Use a minimum of 2 mounting arms per luminaire segment. Mount arms 6" from center of mounting plate to edge of luminaire. Refer to the spacing diagrams on this page for details.
- 3 Mark location where each mounting arm will be installed. Screw arm base to surface using countersink screws appropriate for surface material.

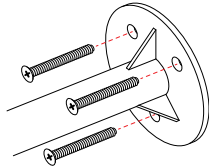

- 4 Screw luminaire to mounting plates through the bottom using countersink holes. Ensure each segment is secured in place and spacing is accurate according to the spacing diagrams.

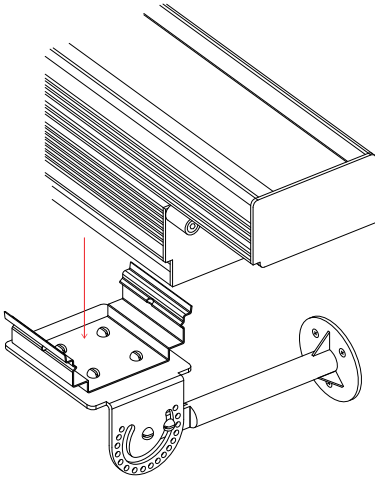

- 5 Loosen set screw until the mounting bracket can move freely. Turn the mounting bracket until desired angle is achieved, then mate the locking bump with locking hole. Tighten set screw until mounting bracket is secured in place.

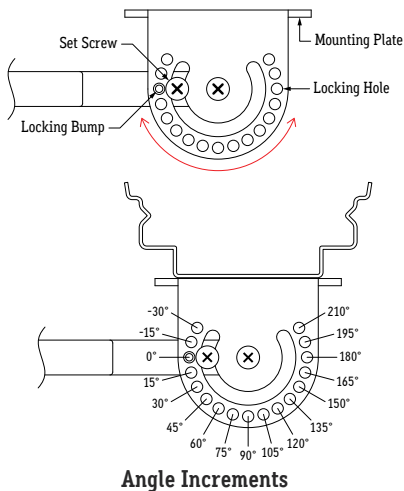

- 6 If applicable, connect disconnects between luminaire segments. Slide shrink tube over connectors and apply heat. The shrink tube will shrink down, sealing the connectors. Apply silicone around sealed connectors for a stronger seal.

Note: Only use a heat gun to apply heat to shrink tubes. Do not use an open flame such as a lighter or gas torch.

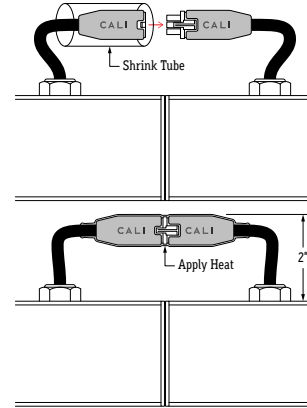

ASSEMBLED END VIEW

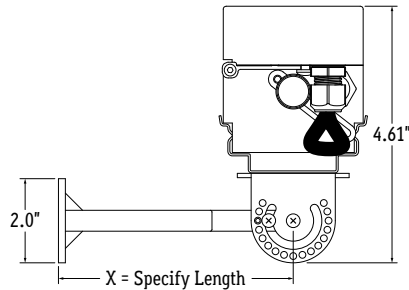

Note: Add 1.01" to overall height for luminaires with lower or reflector installed.

SPACING DIAGRAMS

Example: 4' Luminaire

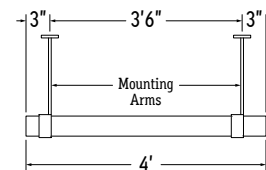

Example: 8' (4' + 4') Luminaire

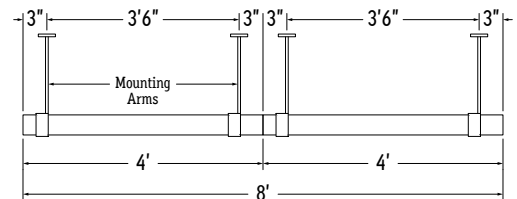

Example: 9' Luminaire (4' + 3' + 2')

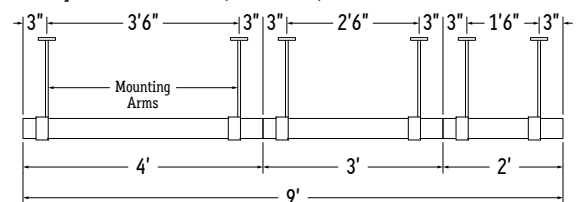

- 1 Measure area where luminaire will be installed. Use a laser line to create a reference along installation area, ensuring accurate placement of mounting arms. Mark location where each mounting arm will be installed along reference line.
- 2 Determine number of mounting arms needed. Use a minimum of 2 mounting arms per luminaire segment. Mount arms 6" from center of mounting plate to edge of luminaire. Refer to the spacing diagrams on this page for details.
- 3 Mark location where each mounting arm will be installed. Screw arm base to surface using countersink screws appropriate for surface material.

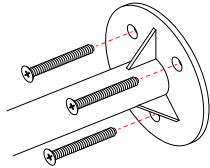

- 4 Screw luminaire to mounting plates through the bottom using countersink holes. Ensure each segment is secured in place and spacing is accurate according to the spacing diagrams.

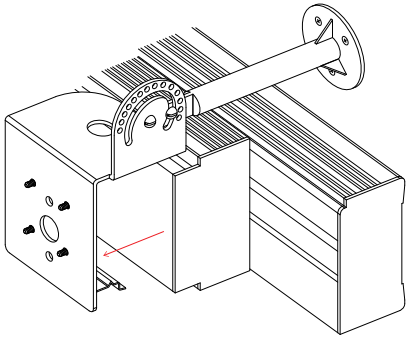

- 5 Loosen set screw until the mounting bracket can move freely. Turn the mounting bracket until desired angle is achieved, then mate the locking bump with locking hole. Tighten set screw until mounting bracket is secured in place.

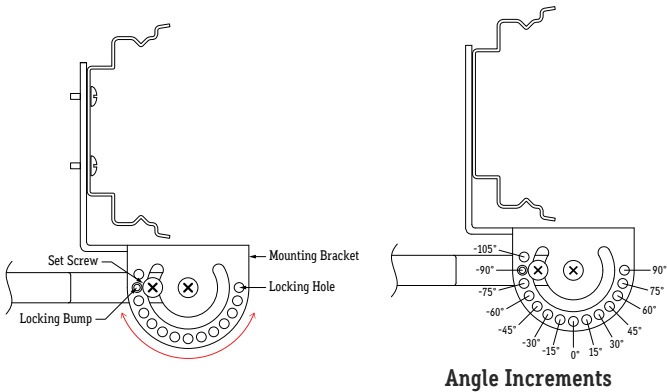

- 6 If applicable, connect disconnects between luminaire segments. Slide shrink tube over connectors and apply heat. The shrink tube will shrink down, sealing the connectors. Apply silicone around sealed connectors for a stronger seal.
Note: Only use a heat gun to apply heat to shrink tubes. Do not use an open flame such as a lighter or gas torch.

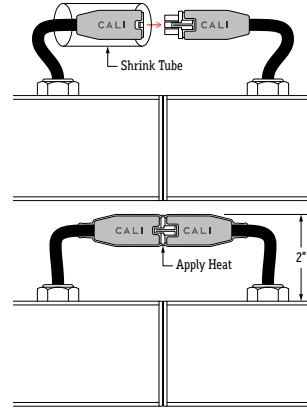

ASSEMBLED END VIEW

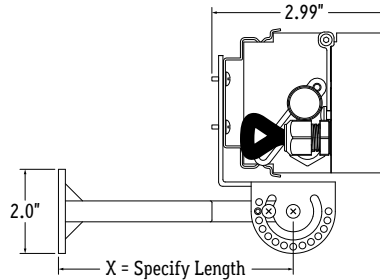

Note: Add 1.01" to overall height for luminaires with louver or reflector installed.

SPACING DIAGRAMS

Example: 4' Luminaire

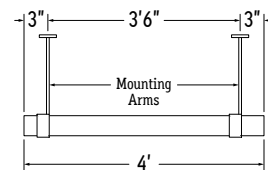

Example: 8' (4' + 4') Luminaire

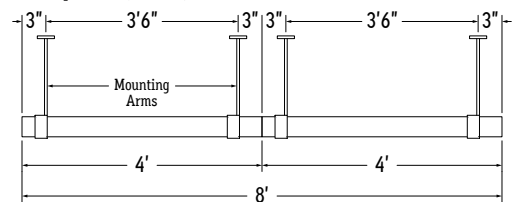

Example: 9' Luminaire (4' + 3' + 2')

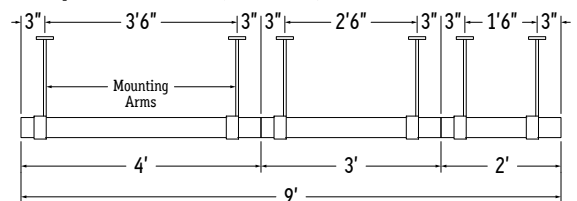

- 1 Determine number of louvers needed for your installation. The louver is available in 1', 2', 3', or 4' lengths.
- 2 Place louver centered on top of luminaire. Match the louver length to the luminaire segment length.
Example: Use a 1' louver for a 1' segment, 2' louver for a 2' segment, and so on.

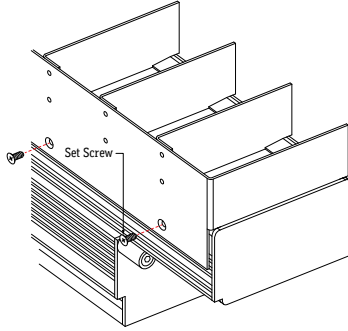

- 3 Install set screws to secure each louver to luminaire. Each louver must be secured using all available set screws. Do not over tighten set screws.

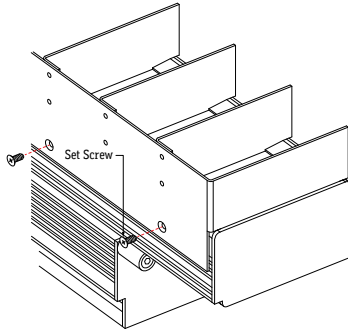

- 4 If applicable, connect disconnects between luminaire segments. Slide shrink tube over connectors and apply heat. The shrink tube will shrink down, sealing the connectors. Apply silicone around sealed connectors for a stronger seal.

Note: Only use a heat gun to apply heat to shrink tubes. Do not use an open flame such as a lighter or gas torch.

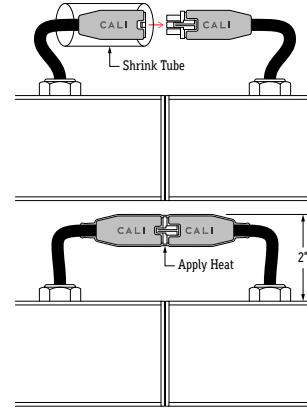

- 5 Luminaires with louver must be mounted a minimum of 12" away from wall.

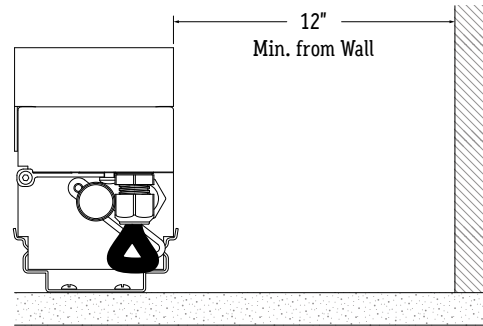

- 1 Determine number of reflectors needed for your installation. The reflector is available in 1', 2', 3', or 4' lengths.
- 2 Place reflectors on luminaire. Match the reflector length to the luminaire segment length.
Example: Use a 1' reflector for a 1' segment, 2' for a 2' segment, and so on.

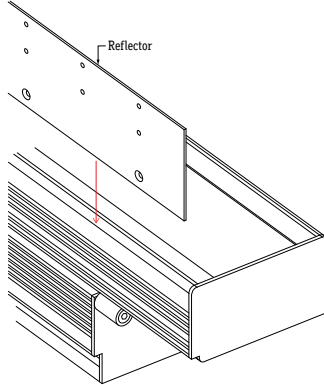

- 3 Install set screws to secure each louver to luminaire. Each louver must be secured using all available set screws. Do not over tighten set screws.

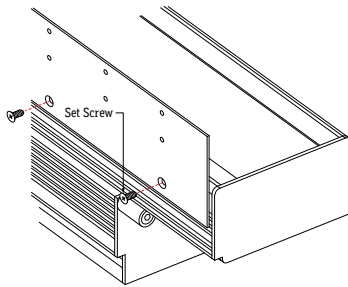

- 4 If applicable, connect disconnects between luminaire segments. Slide shrink tube over connectors and apply heat. The shrink tube will shrink down, sealing the connectors. Apply silicone around sealed connectors for a stronger seal.
Note: Only use a heat gun to apply heat to shrink tubes. Do not use an open flame such as a lighter or gas torch.

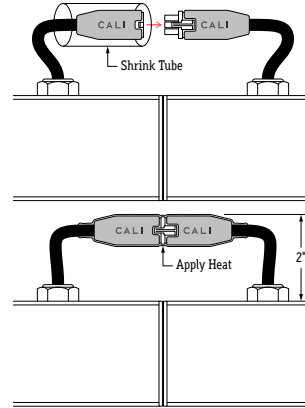

- 5 Luminaires with louver must be mounted a minimum of 12" away from wall.

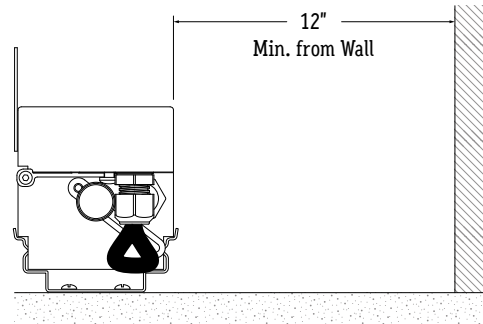
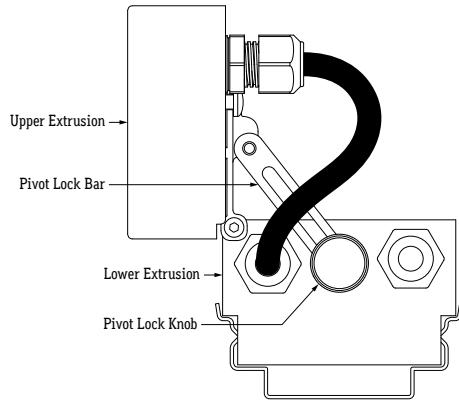
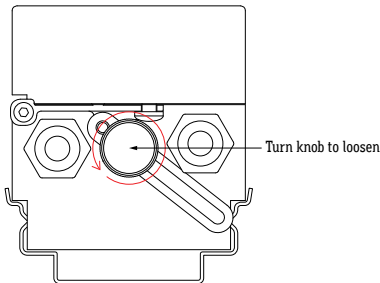

DIAGRAM OF ASSEMBLY



- 1 Slightly unsew Pivot Lock Knobs on both ends of luminaire until Pivot Lock Bar and Upper Extrusion are able to move freely. Do not remove Pivot Lock Knob.



- 2 Adjust angle as desired.
Tip: Use an angle finder or sliding bevel to ensure accuracy of angles.

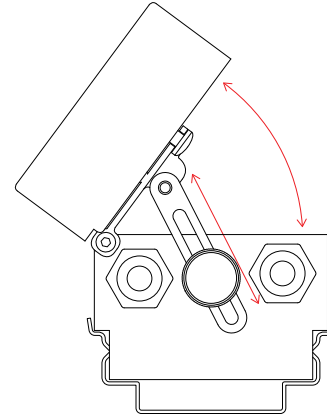

- 3 Turn the Pivot Lock Knob until tight against Pivot Lock Bar. Repeat on other end of luminaire. Do not overtighten Pivot Lock Knob.

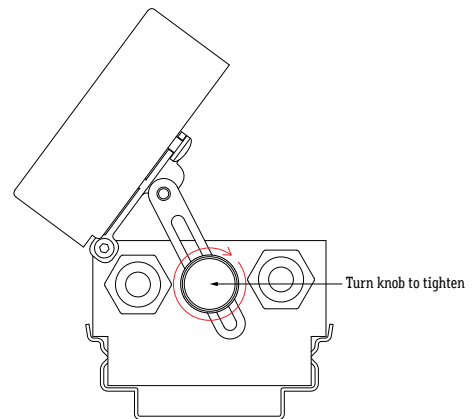

TROUBLESHOOTING TIPS

- Do not reset the breaker multiple times.
- If the unit is overloaded, the breaker will trip, shutting off the driver and lights.
- If the breaker reset button has been held down by hand or any type of pressure, such as duct tape, or if the breaker has been reset multiple times without troubleshooting, the unit will:
 - Burn the driver bobbin.
 - Burn the thermal or magnetic breaker.
 - Burn the driver lead wires due to high amperage caused by overload.
 - Short circuit in line which will not allow the breaker to reset.
 - Damage the lighting.

- 1 Turn off power before beginning. Check for any twisting or damage to the circuit in the LED lightstrip. If there is excessive damage and the circuit is broken, the lightstrip must be replaced.

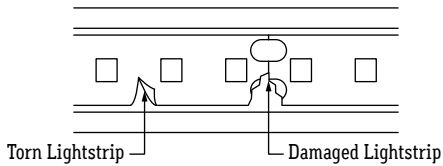

- 2 Check for metal particles or other foreign objects causing the short.

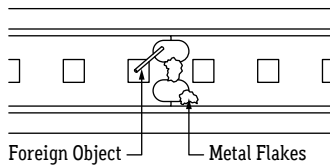

- 3 Check to make sure cuts in the lightstrip are clean and not frayed, causing positive and negative copper pads to touch.

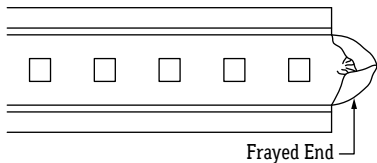

CONTINUITY TEST

A continuity test is performed to determine if electricity can pass through two points on an electrical circuit. This helps identify shorts or malfunctions in the line or luminaire. Use a multimeter or continuity tester to perform the steps below.

- Always perform a continuity test before connecting to power source.
 - Malfunctions are not always as obvious as the lights not turning on.
 - A short or malfunction in the line or luminaire will cause damage over time, irreparably damaging the lighting and voiding warranty.
- 1 Turn off power before beginning. Verify power is off by using a non-contact circuit tester (by others). Touch the probe of the tester to the positive wire of the power source. The tester will light up if an electrical current is detected.
 - 2 Setup your multimeter tester (by others). First, insert the black probe lead into the COM jack, then insert the red probe lead into the VΩ jack.

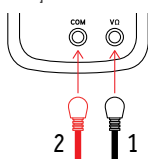

- 3 Verify multimeter is functional by touching probes together. The multimeter should beep, flash, or read 0Ω (ohms) of resistance.
- 4 Touch the red probe to the luminaire extrusion and the black probe to the ground wire (green). If the luminaire is properly grounded, the multimeter will beep, flash, or read 0Ω (ohms). If there is no conductive path, the multimeter will not show any feedback. Troubleshoot to identify the malfunction in the ground wire.

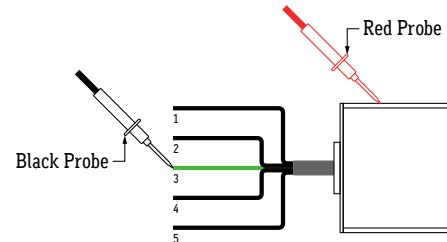

- 5 Touch the red probe to any wire and the black probe to each other wire. Repeat process for each wire. If a conductive path is formed between any of the wires, the multimeter will beep, flash, or read 0Ω (ohms). Troubleshoot to identify the malfunction in the line. If there is no conductive path, the multimeter will not show any feedback.

Example: Check for continuity between Wire 2 and Wire 4

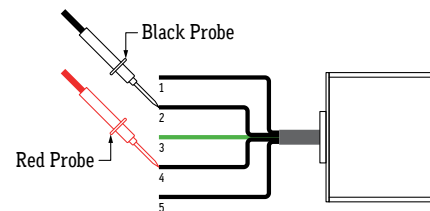

- 6 Touch the red probe to the luminaire housing and the black probe to each wire except ground. If a conductive path is formed between the housing and any of the wires, the multimeter will beep, flash, or read 0Ω (ohms). Troubleshoot to identify the malfunction in the line. If there is no conductive path, the multimeter will not show any feedback.

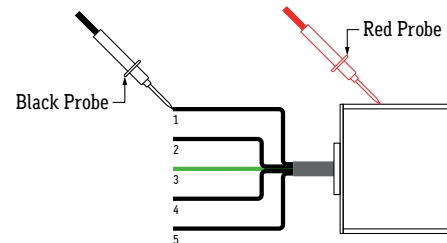

- 7 Set multimeter to AC voltage and test power source. Confirm the correct voltage before connecting luminaire to power source. If the voltage reading is more than 1 volt greater than the marked output voltage, there is a problem with the power source or driver.
- 8 Connect luminaire to power source. If LEDs do not turn on, troubleshoot to find the problem in the line.

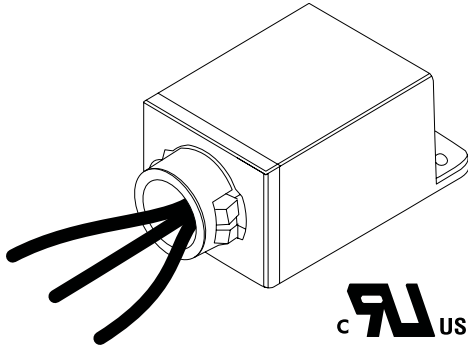

CASE DIMENSIONS

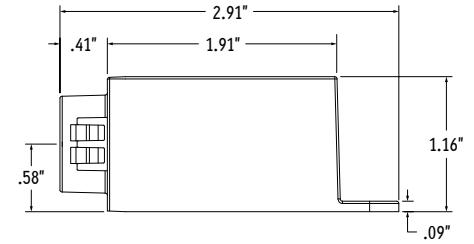
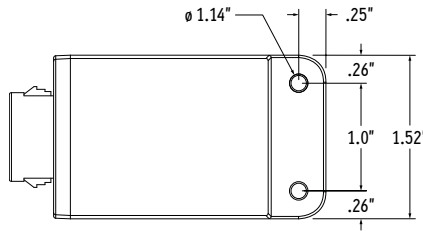

SURGE PROTECTOR SPECIFICATIONS

MODEL	INPUT VOLTAGE	SURGE PROTECTION LEVEL	MOUNTING	ENCLOSURE MATERIAL	INPUT LEADS	INPUT FREQUENCY
ALS-SP	120V - 277V	10kV, 10kA, ANSI C62.41 Category C	SnapLOCK / Footed	Polycarbonate	6", 18AWG stranded, 105°C stripped, 3/8" tinned	60Hz

PRODUCT FEATURES

The Surge Series are 3-leaded devices that protect Line-Ground, Line-Neutral, and Neutral-Ground in accordance with IEEE / ANSI C62.41.2 guidelines. Protects against surges according to IEEE C62.41.2 C High (10kA and 10kV). Surge current rating = 10,000 Amps using industry standard 8/20 μ Sec wave. Surge Location Rated Category C3. UL Recognized Component in the United States and Canada (UL1449). Type 4 Surge Protection Device. High temperature, flame retardant plastic enclosure, 85°C maximum surface temperature rating. Thermally Protected Transient Over-voltage Circuit.

PRODUCT SPECIFICATIONS

The Surge series of products are designed to be used in conjunction with LED Drivers and fixtures to provide an additional level of protection against powerline disturbances in industrial, commercial and residential applications where surge protection to IEEE C62.41.2 is required.

0-10V WIRING DIAGRAM (10V Dimming)

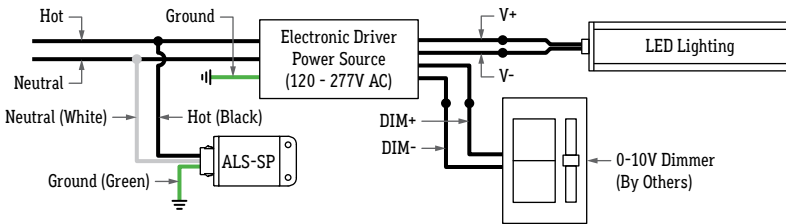

Note: Wire colors vary based on model. See individual TRA-E submittal for more information, or refer to wire callouts on transformer labeling. Always confirm wire colors before connecting to power source.