

Perspective View

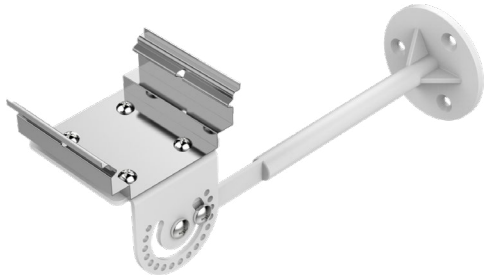

1. Measure area where luminaire will be installed. Use a chalk line to ensure a straight installation.
2. Determine number of mounting arms needed. Use a minimum of 2 mounting arms per luminaire. Mount arms 6" from center of mounting plate to end of luminaire.
Note: Refer to Spacing Diagrams on page 2
3. Mark location where mounting arms will be installed. Screw arm base to surface using countersink screws of appropriate type and length for surface material.

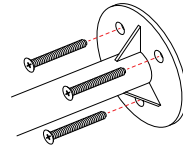

4. Secure luminaire to mounting plates by installing provided #6-20 countersink screws holes through countersink holes in the bottom of the plate. Ensure fixture is secured in place and spacing is accurate according to the Spacing Diagrams on page 2.

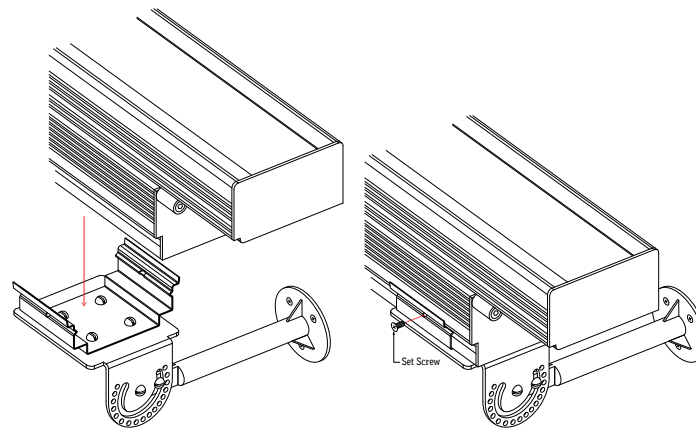

5. Loosen set screw until the mounting plate can move freely. Turn the mounting plate until desired angle is achieved, then mate the locking bump with locking hole. Tighten set screw until mounting plate is secured in place.

Note: Refer to Angle Increments diagram on page 2.

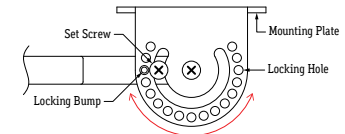

6. If applicable, connect disconnects between luminaires. Slide shrink tube over connectors and apply heat. The shrink tube will shrink down, sealing the connectors. Apply silicone around sealed connectors for a stronger seal.

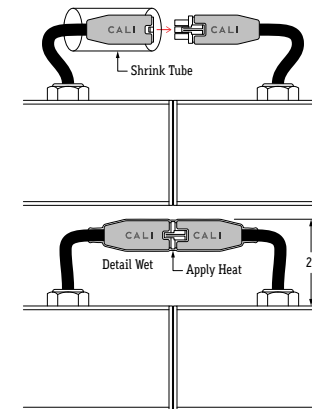

Assembled End Views

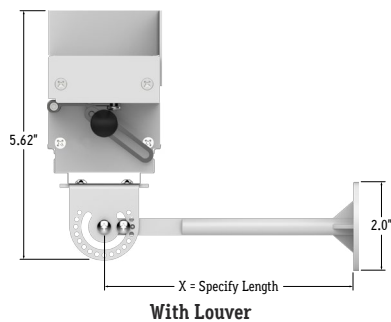
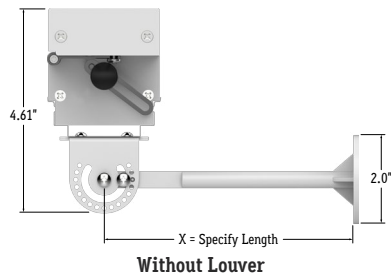

MOUNTING ARM SPACING DIAGRAMS

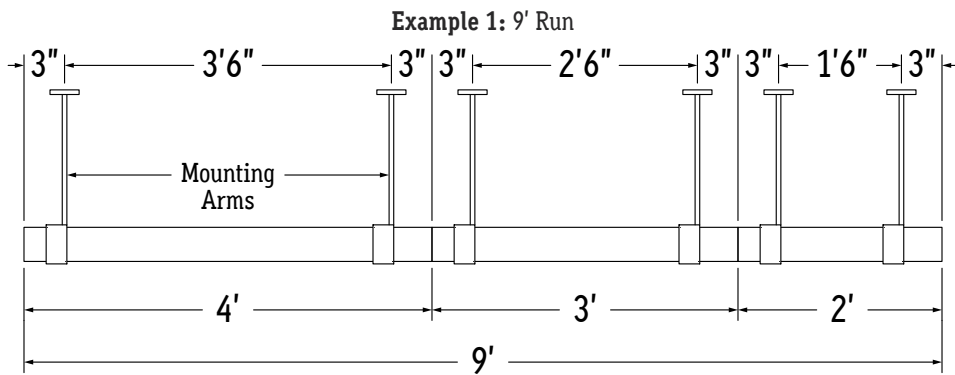
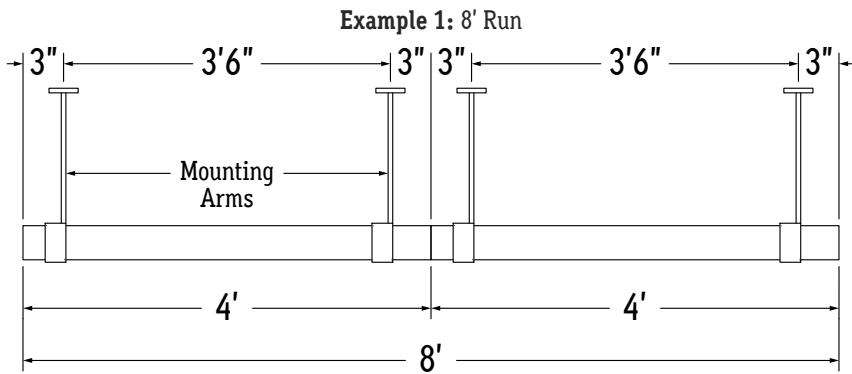
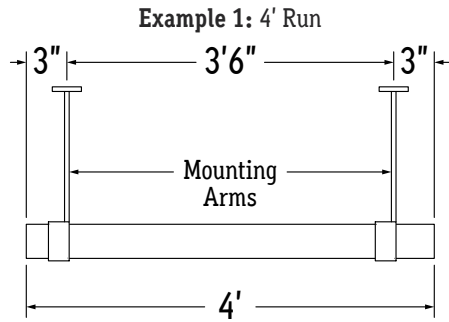

ANGLE INCREMENTS DIAGRAM

